

ECO PHYSICS CLD 82 Mh

Application examples



Online quality control in production lines- QAL 1 approved
Stack emission measurement
Operation of boiler and burner
Waste incineration plants
Power generating turbines
Metal foundries

The CLD 82 Mh NO_x analyzer is the ideal instrument for certified series checks. It is distinguished by the high precision and reliable, continuous operation. QAL 1 approved analyzer.



Simply ingenious.

The CLD 82 Mh single channel nitrogen oxide analyzer is designed for all applications with an existing gas pre-conditioning unit to ensure QAL quality control as well as keeping to threshold values.

The design is remarkably compact. All components, even the vacuum pump and the thermal ozone scrubber, are contained in one single unit. In spite of its simple construction the high ECO PHYSICS standard is fully complied with. The instrument includes a temperature stabilized photo multiplier and a high performance ozone generator.



Modularity means easy maintenance.

Thanks to its completely modular interior the analyzer is easy to service. The reaction chamber can be removed for cleaning or replacement by following a few simple steps as shown in the picture.

Many more applications are available as options or upgrades at a later date.



The CLD 82 Mh with slides is perfectly prepared for rack mounting.

Simply user friendly.

The user can choose from four measurement ranges between 5 and 5000 ppm. The analyzer can be operated via the keypad and remotely from a personal computer. The easy-to-read display with 2 lines of 40 characters each facilitates the gas readings and clarifies the command structure. Simple, intuitive commands are the key to full test procedures tailored to the user's needs. Even system integration can be comfortably planned and easily realized.

The analyzer operates extremely reliably and with outstanding precision.

Its design guarantees ease of use and a minimum of maintenance. The oil-free vacuum pump, for example, only needs to be checked once every 12 months.

- Four freely selectable measurement ranges up to 5000 ppm NO/NO_x
- Local user guidance
- Operation and control via keypad or personal computer
- Error message coded and in full text
- Rapid system integration
- Virtually maintenance-free even in continuous operation.



CLD 82 Mh

Specifications

<i>Measuring ranges</i>	four freely selectable ranges from 5–5000 ppm	<i>Supply voltage</i>	100 - 230 V/50–60 Hz
<i>Min. detectable concentration</i>	0.25 ppm*	<i>Interface</i>	RS 232 (standard)
<i>Noise at zero point (1 σ)</i>	0.125 ppm*	<i>Analog output</i>	4–20 mA into 500 Ω max.; 0–1 V; 0–10 V
<i>Lagtime</i>	<1 sec	<i>Dimensions</i>	height: 133 mm (5¼") width: 450 mm (19") with moulding: 495 mm depth: 545 mm
<i>Rise time (0–90%)</i>	<1 sec	<i>Weight</i>	21 kg
<i>Temperature range</i>	5–40 °C	<i>Delivery includes</i>	CLD 82 S analyzer, power cable, analog signal cable, manual
<i>Humidity tolerance</i>	5–95% rel. h (non-condensing, ambient air and sample gas)	<i>Standard</i>	CLD 82 Mh Molybdenum converter heated gas inlet
<i>Quenching (with gas cooler)</i>	for H ₂ O: <1.5% of meas. value□ for CO ₂ : <0.3%/vol.-% CO ₂	<i>Interface Options</i>	LAN LAN interface
<i>Sample flow rate</i>	0.05 l/min. (1.2 l/min with option r)		
<i>Input pressure</i>	externally stabilized within ± 3 mbar		
<i>Dry air use for O₃ generator</i>	internally generated (no external supply gas required)		
<i>Power required</i>	400 VA (incl. membrane pump and ozone scrubber)		

* depending on filter setting

ECO PHYSICS reserves the right to change these specifications without notice.

Flow diagram

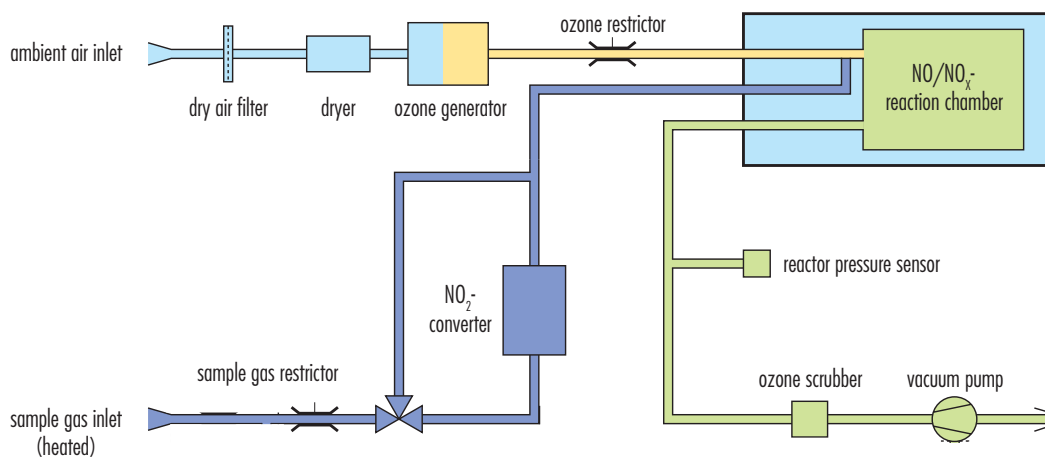

ECO PHYSICS

ECO PHYSICS AG · POB 282 · CH-8635 DUERNEN · TEL. +41 55 220 22 22 · FAX +41 55 220 22 55 · E-MAIL INFO@ECOPHYSICS.COM
WWW.ECOPHYSICS.COM